

PHYS 1441 – Section 002

Lecture #10

Monday, Oct. 5, 2009

Dr. Jaehoon Yu

- Newton's Third Law
- Categories of forces
- Application of Newton's Laws
- Force of Friction
 - Motion with friction
- Uniform Circular Motion

Today's homework is homework #6, due 9pm, Tuesday, Oct. 13!!

Monday, Oct. 5, 2009



PHYS 1441-002, Fall 2009 Dr. Jaehoon Yu

1

Announcements

- Second term exam
 - Non-comprehensive exam
 - Wednesday, Nov. 4
 - Mark your calendars!!



Newton's Third Law (Law of Action and Reaction)

If two objects interact, the force F_{21} exerted on object 1 by object 2 is equal in magnitude and opposite in direction to the force F_{12} exerted on object 2 by object 1.

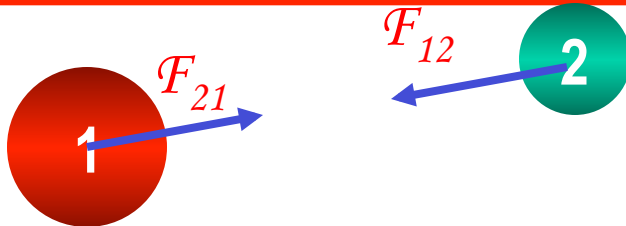

$$\vec{F}_{12} = -\vec{F}_{21}$$

The action force is equal in magnitude to the reaction force but in opposite direction. These two forces always act on different objects.

What is the reaction force to the force of a free falling object?

The gravitational force exerted by the object to the Earth!

Stationary objects on top of a table has a reaction force (called the normal force) from table to balance the action force, the gravitational force.

Special Project for Extra Credit

A large man and a small boy stand facing each other on **frictionless ice**. They put their hands together and push against each other so that they move apart. a) Who moves away with the higher speed and by how much? b) Who moves farther in the same elapsed time?

- Derive formulae for the two problems above in much more detail than what is shown in this lecture note.
- Be sure to clearly define each variables used in your derivation.
- Each problem is 10 points each.
- Due is Wednesday, Oct. 14.



Ex. The Accelerations Produced by Action and Reaction Forces

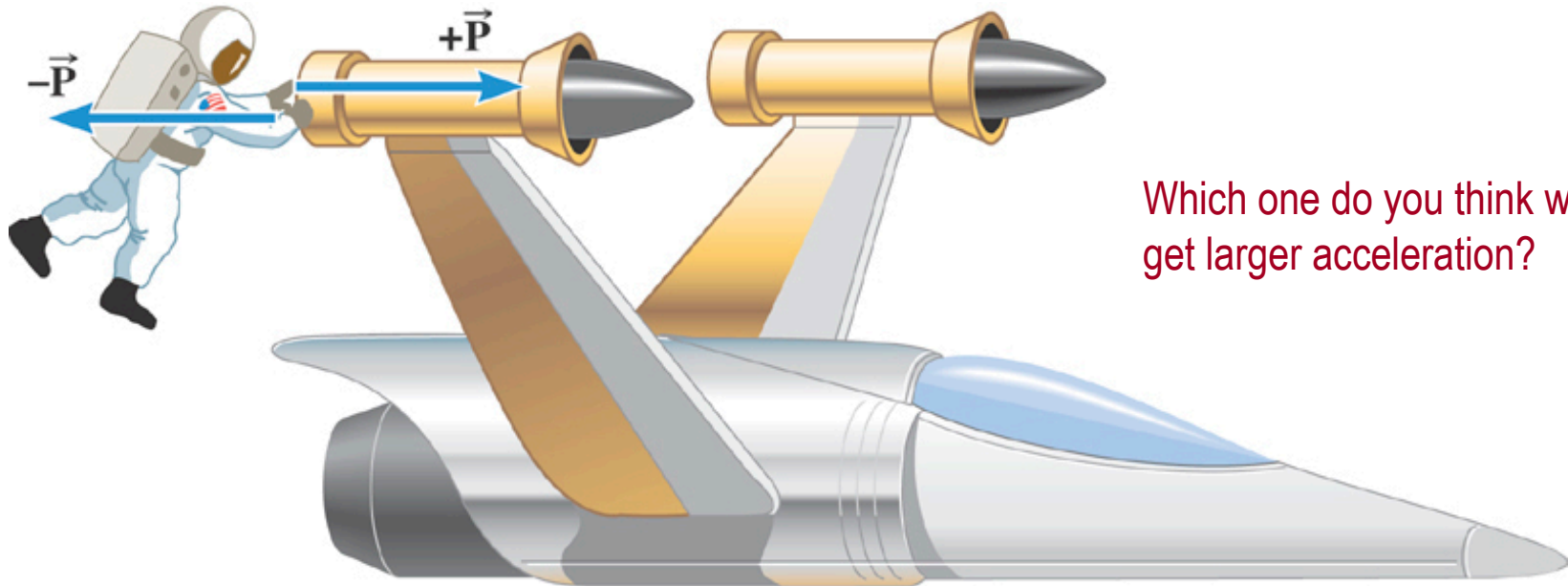

Which one do you think will get larger acceleration?

Suppose that the magnitude of the force is 36 N. If the mass of the spacecraft is 11,000 kg and the mass of the astronaut is 92 kg, what are the accelerations?

Ex. continued

Force exerted on the space craft by the astronaut $\sum \vec{F} = \vec{P}$.

Force exerted on the astronaut by the space craft $\sum \vec{F} = -\vec{P}$.

space craft's acceleration $\vec{a}_s = \frac{\vec{P}}{m_s} = \frac{+36 \vec{i} \text{ N}}{11,000 \text{ kg}} = +0.0033 \text{ m/s}^2$

astronaut's acceleration $\vec{a}_A = \frac{-\vec{P}}{m_A} = \frac{-36 \vec{i} \text{ N}}{92 \text{ kg}} = -0.39 \text{ m/s}^2$

Example of Newton's 3rd Law

A large man and a small boy stand facing each other on **frictionless ice**. They put their hands together and push against each other so that they move apart. a) Who moves away with the higher speed and by how much?

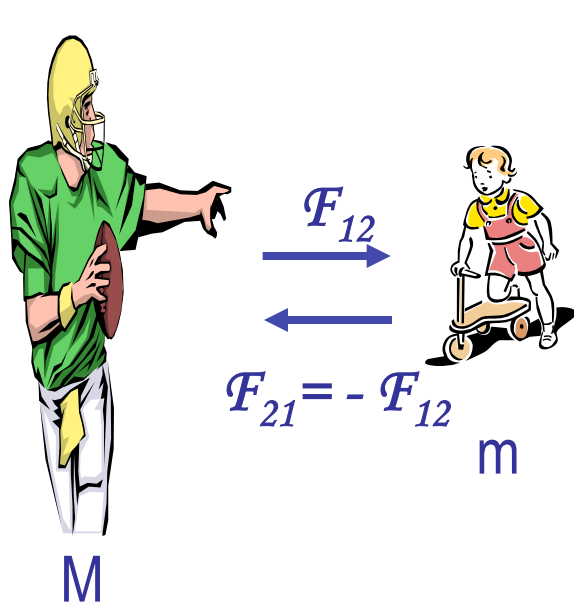

$$\vec{F}_{12} = -\vec{F}_{21}$$

$$\vec{F}_{12} = m\vec{a}_b$$

$$\vec{F}_{21} = M\vec{a}_M$$

$$|\vec{F}_{12}| = |\vec{F}_{21}| = F$$

$$F_{12x} = ma_{bx}$$

$$F_{12y} = ma_{by} = 0$$

$$F_{21x} = Ma_{Mx}$$

$$F_{21y} = Ma_{My} = 0$$

Since $\vec{F}_{12} = -\vec{F}_{21}$ and $|\vec{F}_{12}| = |-\vec{F}_{21}| = F$

Establish the equation

$$ma_{bx} = F = Ma_{Mx}$$

Divide by m

$$a_{bx} = \frac{F}{m} = \frac{M}{m} a_{Mx}$$

Example of Newton's 3rd Law, cnt'd

Man's velocity $\rightarrow v_{Mxf} = v_{Mxi} + a_{Mx}t = a_{Mx}t$

Boy's velocity $\rightarrow v_{bxf} = v_{bxi} + a_{bx}t = a_{bx}t = \frac{M}{m}a_{Mx}t = \frac{M}{m}v_{Mxf}$

So boy's velocity is higher than man's, if $M > m$, by the ratio of the masses.

b) Who moves farther while their hands are in contact?

Boy's displacement $\rightarrow x_b = v_{bxi}t + \frac{1}{2}a_{bx}t^2 = \frac{M}{2m}a_{Mx}t^2$

$x_b = \frac{M}{m} \left(\frac{1}{2}a_{Mx}t^2 \right) = \frac{M}{m}x_M$

Man's displacement

Given in the same time interval, since the boy has higher acceleration and thereby higher speed, he moves farther than the man.

Categories of Forces

- Fundamental Forces: Truly unique forces that cannot be derived from any other forces
 - Total of three fundamental forces
 - Gravitational Force
 - Electro-Weak Force
 - Strong Nuclear Force
- Non-fundamental forces: Forces that can be derived from fundamental forces
 - Friction
 - Tension in a rope
 - Normal or support forces



The Normal Force

The normal force is one component of the force that a surface exerts on an object with which it is in contact – namely, the component that is **perpendicular to the surface**.

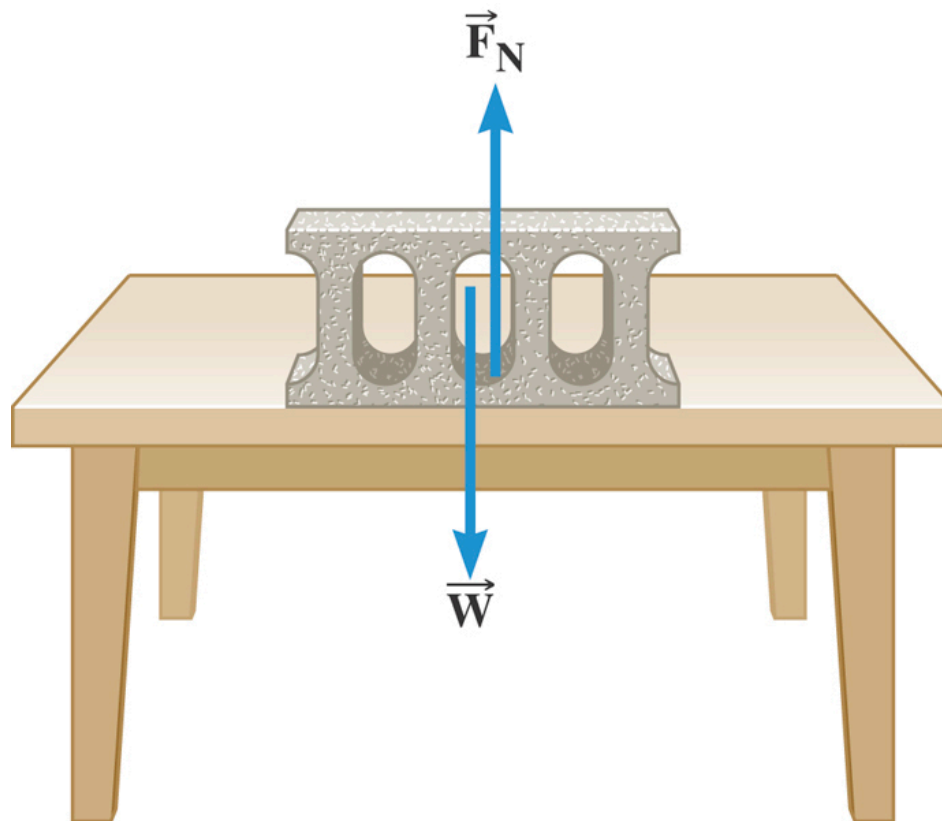

Some normal force exercises

Case 1: Hand pushing down on the book

$$F_N - 11 \text{ N} - 15 \text{ N} = 0$$

$$F_N = 26 \text{ N}$$

Case 2: Hand pulling up the book

$$F_N + 11 \text{ N} - 15 \text{ N} = 0$$

$$F_N = 4 \text{ N}$$

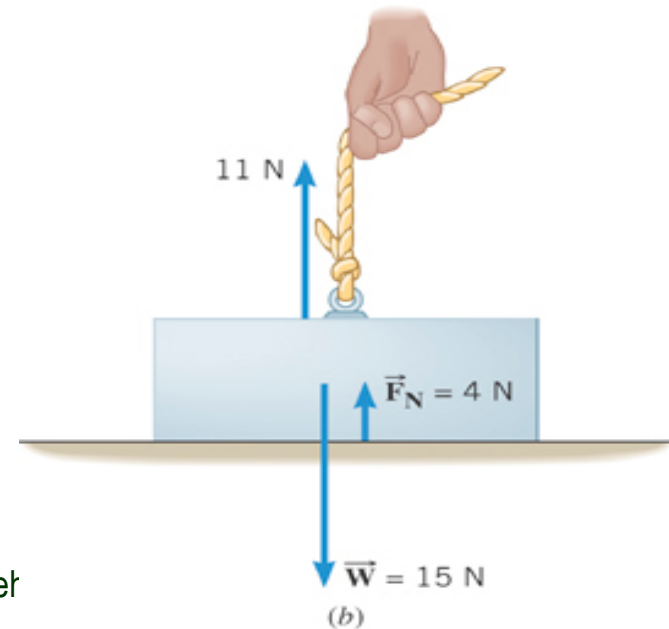
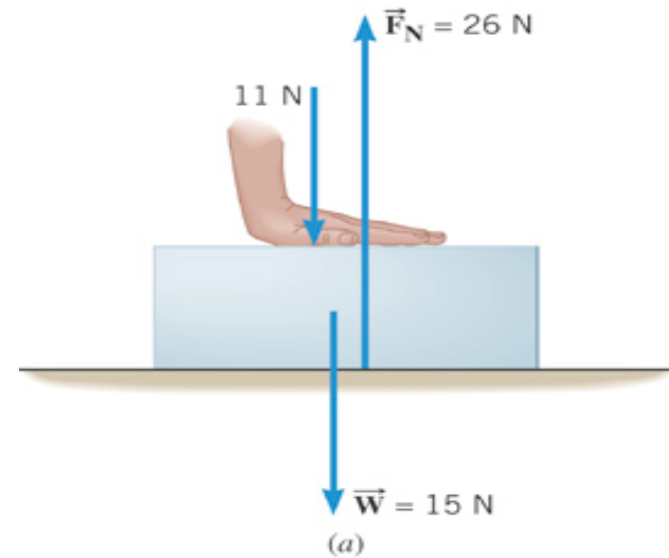

Monday, Oct. 5, 2009



PHYS 1441-002, Fall 2009 Dr. Jaef Yu

Some Basic Information

When Newton's laws are applied, *external forces* are only of interest!!

Why?

Because, as described in Newton's first law, an object will keep its current motion unless non-zero net external force is applied.

Normal Force, n :

Reaction force that reacts to action forces due to the surface structure of an object. Its direction is perpendicular to the surface.

Tension, T :

The reactionary force by a stringy object against an external force exerted on it.

Free-body diagram

A graphical tool which is a diagram of external forces on an object and is extremely useful analyzing forces and motion!! Drawn only on an object.

Free Body Diagrams and Solving Problems

- Free-body diagram: A diagram of vector forces acting on an object
- ▶ A great tool to solve a problem using forces or using dynamics
- 1. Select a point on an object in the problem
- 2. Identify all the forces acting only on the selected object
- 3. Define a reference frame with positive and negative axes specified
- 4. Draw arrows to represent the force vectors on the selected point
- 5. Write down net force vector equation
- 6. Write down the forces in components to solve the problem
- ▶ No matter which one we choose to draw the diagram on, the results should be the same, as long as they are from the same motion

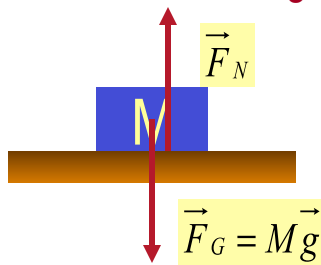

Which one would you like to select to draw FBD? Let's take box!
 What do you think are the forces acting on this object?

Gravitational force

the force supporting the object exerted by the floor

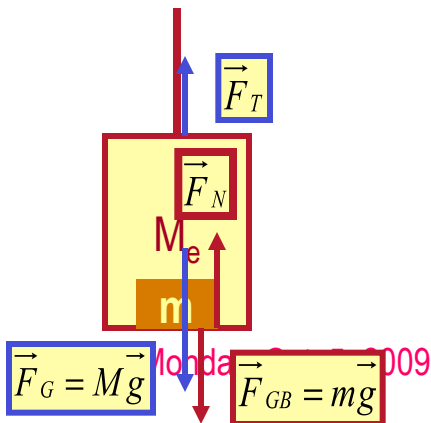
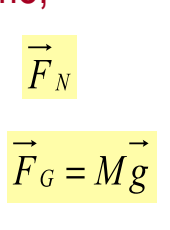

Which one would you like to select to draw FBD?

What do you think are the forces acting on this elevator?

Gravitational force

The force pulling the elevator (Tension)

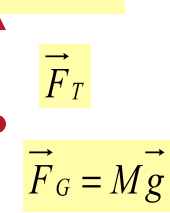

What about the box in the elevator?

Gravitational force

Normal force

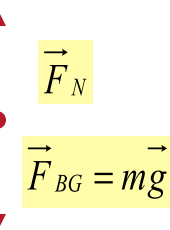

Applications of Newton's Laws

Suppose you are pulling a box on frictionless ice, using a rope.

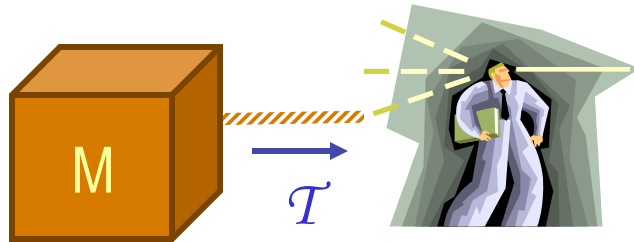

What are the forces being exerted on the box?

Gravitational force: F_g

Normal force: n

Tension force: T

Free-body diagram

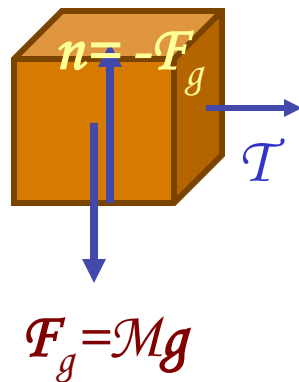

Total force:

$$F = F_g + n + T = T$$

$$\sum F_x = T = Ma_x$$

$$a_x = \frac{T}{M}$$

$$\sum F_y = -F_g + n = Ma_y = 0$$

$$a_y = 0$$

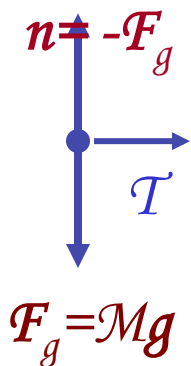

If T is a constant force, a_x is constant

$$v_{xf} = v_{xi} + a_x t = v_{xi} + \left(\frac{T}{M} \right) t$$

$$\Delta x = x_f - x_i = v_{xi} t + \frac{1}{2} \left(\frac{T}{M} \right) t^2$$

Friction Force

When an object is in contact with a surface there is a force acting on that object. The component of this force that is parallel to the surface is called the **friction force**. *The resistive force is exerted on a moving object due to viscosity or other types of frictional property of the medium in or surface on which the object moves.* *Always opposite to the movement!!*

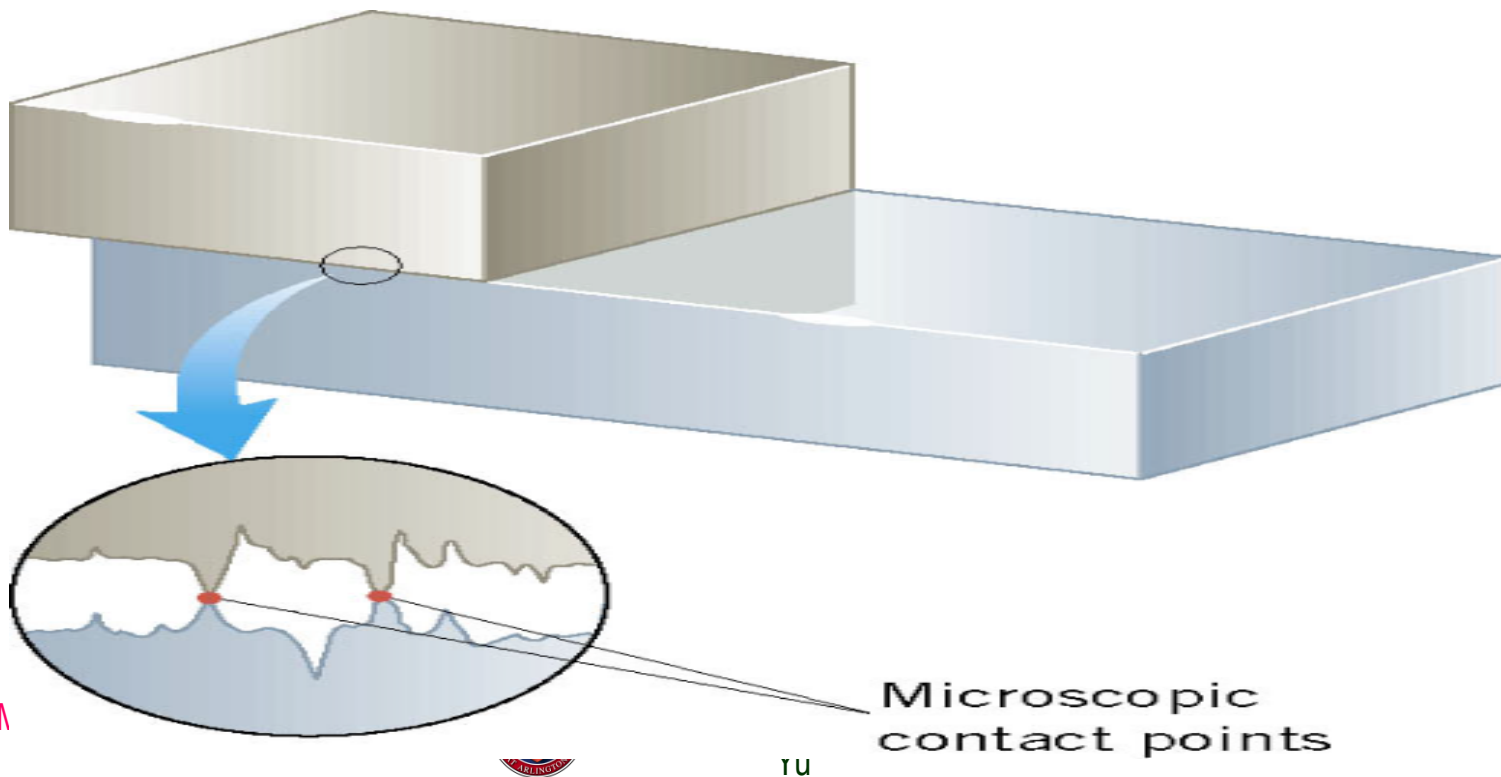

Static Friction

When the two surfaces are not sliding across one another the friction is called **static friction**. The resistive force exerted on the object up to the time just before the object starts moving.



No movement
(a)



No movement
(b)



When movement just begins
(c)

Magnitude of the Static Friction

The magnitude of the static friction force can have any value from zero up to the maximum value.

$$f_s \leq f_s^{MAX}$$

$$f_s^{MAX} = \mu_s F_N$$

$0 < \mu_s < 1$ is called the coefficient of static friction.

What is the unit? None

Once the object starts moving, there is **NO MORE** static friction!!

Kinetic friction applies during the move!!



Note that the magnitude of the frictional force does not depend on the contact area of the surfaces.

$$f_s^{MAX} = \mu_s F_N$$

